



medical **ECONET**  
GERMANY

# defiMASTER

Biphasic Defibrillation and monitoring



## Manual defibrillator and monitoring device.

The defiMASTER is the latest defibrillator/monitoring system from medical ECONET, which has been specially designed for professional use, e.g. by rescue services or in hospitals.

As a versatile all-rounder, it is characterised on the one hand by a variable shock output from 1 to 360 joules of output energy and an automatic changeover function for the resuscitation of adults and children. On the other hand, our new defibrillator monitor provides all functions and parameters that a modern monitoring monitor has to offer.

When every second counts to save a human life, you can be sure that the defiMASTER will prove to be a reliable helper in everyday life.

### Features and Benefits

- Defibrillation Mode, Monitor Mode, AED Mode and Pacing Mode are all in one
- Cardioversion function enables to deal with atrial fibrillation.
- Internal defibrillation function enables open chest defibrillation.
- 1~360 joules energy selectable.
- Implementing the custom shock sequence by applying Energy escalation function.
- Patient Impedance Range: 25 ~200ohm.
- Optional 12 leads ECG diagnosis function (Glasgow algorithm).
- Automatically change energy based on choice and possible selection of adult and child patients.
- Built-in 5 countries voices / text guide selectable (voice / text group can be specified).
- CPR feedback function enables effective CPR implementation. (Option)
- Voice recording confirms and strengthens on-site measures.
- Multi-parameter function – SpO<sub>2</sub>, 2 IBP, 2 temp. EtCO<sub>2</sub>, NIBP. (Option)
- Ambulance holder – Enhances usability by applying rechargeable wall mount.(Option)
- Bed rail function enables patient bed to be fixed, enhancing usability.
- 2 batteries installed, extending the battery life to 9 hours.
- Pacing current max 140mA, 40mS possible.
- Equipped with 80mm thermal printer leads to expressing 3-channel waveforms.

# defiMASTER

Biphasic Defibrillation and monitoring

## Comfortable design and intuitive display

- Biphasic defibrillation, pacing and complete monitoring including a powerful memory to store numerical data (ECG, EtCo2 and IBP waveforms) in a portable device / storage of data of up to 100 patients and 250 events
- Offers a full range of monitoring options including 3/5/12 channel ECG (Glasgow Algorithm), SpO2, AED, NIBP, IBP, Temp and Respiration EtCO2
- Ergonomic carrying handle with holding function on the back of the device for patient beds or rescue couches to improve user-friendliness and mobility



## Biphasic Defibrillation, Pacing and Complete Monitoring in one Portable Device

- Multifunctional Defibrillator / Monitor
- Manual and AED Operation
- Non-invasive Pacing Mode
- Advanced Biphasic Technology
- Defibrillation with Paddles
- Internal defibrillation with Internal spoons
- 12 Lead ECG Monitoring

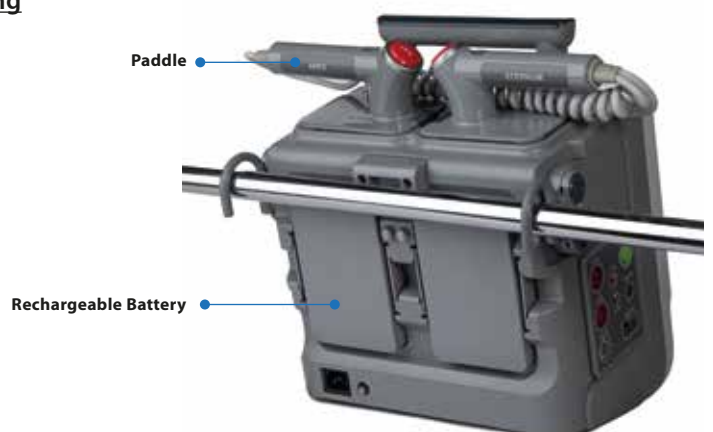

# defiMASTER

Biphasic Defibrillation and monitoring

## Including Glasgow 12-Lead ECG Algorithm

For the last 30 years the Glasgow Algorithm has been improved and updated to become a go-to algorithm for cardiologists around the globe. The proven performances as an advantage of clinical usage for STEMI analysis is a given.



**STEMI:**

ST-Elevation Myocardial Infarction (STEMI) is a very serious type of heart attack during which one of the heart's major arteries (one of the arteries that supplies oxygen and nutrient-rich blood to the heart muscle) is blocked. ST-segment elevation is an abnormality detected on the 12-lead ECG.

The Glasgow program follows the AHA recommendation for STJ measurement at the J point for STEMI which is helpful to analyze the STEMI, it also includes criteria for left bundle branch blocks (LBBBs) which increase the risk of a reporting error in data in the STEMI analysis. The 12 ECG algorithm (Glasgow type) can even differentiate between age and gender in the STEMI analysis. This is one of the factors that make professionals diagnose STEMI more accurately.

	<b>GLASGOW (defiMASTER)</b>	<b>COMPANY Z</b>	<b>COMPANY P</b>
Pediatric Interpretation	<b>YES</b>	NO	YES
LBBB criteria for STEMI	<b>YES</b>	NO	YES
ST Measurement at J Point	<b>YES</b>	NO	YES
Published results from testing with prehospital ECGs	<b>4 studies</b>	1 study	No study

# defiMASTER

Biphasic Defibrillation and monitoring

## Comparison defiMASTER with other Brands.

	<b>defiMASTER</b>	<b>COMPANY Z / X</b>	<b>COMPANY P / 15</b>	<b>COMPANY P / HS</b>
Waveform	<b>Biphasic BTE</b>	Biphasic (Rectilinear)	Biphasic BTE	Biphasic BTE
Energy level in Manual mode	1-10,15,20,30,40,50,75,100,125,150,175,200, <b>300,360J</b>	1-10,15,20,30,50,70,85,100,120,150,200J	2-10,15,20,30,50,70,100,125,150,175,200,225,250,275,300,325,360J	1-10,15,20,30,50,70,100,120,150,170,200J
Charge time	<b>&lt;5 sec. For 200J</b> <b>&lt;8 sec. For 360J</b>	<7 sec. For 200J	<10 sec. For 360J	<5 sec. For 200J
Paddle's controls	Charge, Shock, Energy select	Charge, Shock, Energy select, Recorder	Charge, Shock, Energy select, Print	Charge, Shock
Energy level semiautomatic mode	120, 150, 200J	120, 150, 200J	150-360J	Fixed at 150J
Voice messages	Available	Available	Available	Available
Self test	Automatic Daily, Weekly, Monthly self-test	self-test of audio & visual alarm indicators upon power-up	Daily, 3AM diagnostic self-test	Automatic daily and weekly self-test with state indicator
<b>MONITOR</b>				
Screen type	LCD	LCD	LCD	LCD
Screen size	<b>8,4" diagonal</b> <b>Resolution 800x600</b>	6,5" diagonal Resolution 640 x 480	8,4" diagonal Resolution 640 x 480	8,4" diagonal Resolution 640 x 480
Channels	Up to 4 ECG traces and 12 ECG traces	Up to 4 ECG traces and 12 ECG traces	Up to 3 ECG traces	Up to 4 ECG traces and 12 ECG traces
PaceMaker pulse filter	<b>Available</b>	Available	?	Available
ECG size	<b>Auto, 5.0, 10.0, 15.0, 20.0, 30.0, 40.0 mm/mV</b>	Auto, 1.25, 2.5, 5.0, 10.0, 20.0, 40.0 mm/mV	2.5, 5.0, 10.0, 15.0, 20.0, 25.0, 30.0, 40.0 mm/mV	2.5, 5, 10, 20, 40 mm/mV

# defiMASTER

Biphasic Defibrillation and monitoring

## Specifications

### Display

Screen Size:	8,4" TFT-LCD
Screen Type/Color:	Liquid Crystal Display (LCD) Color
Resolution:	170 x 128 mm

### Controls

Multifunction Knob, Mode selection Knob (Power Off, AED, Manual, Monitor and Pacing), 12 function buttons (Paddle energy selection, Patient selection, ECG Lead change, ECG size change, Print, Paddle charge, Energy selection, charge, ECG analyze, Shock, Sync, Event, Alarm), 5 soft keys.

### Alarms

Categories:	Patient Status and System Status
Priorities:	Low, Medium and High Priorities
Notification:	Audible and Visual
Setting:	Default and Individual
Alarm Volume Level:	45 - 85 dB

### Physical Characteristics and Printer

Dimensions:	310 x 290 x 215 (mm) (W H D)
Weight:	6.5 kg

### Internal paddle

Type	Length	Weight
Spoon 16 cm <sup>2</sup>	16 cm	80 g
Spoon 32 cm <sup>2</sup>	23 cm	270 g
Spoon 54 cm <sup>2</sup>	24,5 cm	310 g
Interface cable	3,6 m	540 g
Trunk cable	66 cm	190 g

### Printer

Type:	Thermal
Weight:	190 g
Number of Channels:	1 - 3 channels
Paper Type:	Thermal transfer paper
Paper Width:	80 mm
Printer Speed:	25 mm/sec, 50 mm/sec

### Electrical

Power Requirement AC Mains 100-240 V, 50/60 Hz, 140-130 VA

#### Battery (Option)

Type:	Li-ion battery
Dimensions:	105,4 x 143,97 x 36 mm (W H D)
Voltage/Capacity:	4S2P 14.52V / 6600 mAh
Discharge:	A minimum of 200 shocks at 200 Joules (per battery)
Operating Time:	5 hours (per battery) at the following conditions: no printing, no external communication, no audible alarm sound, room temperature: 25°C
Recharging Time:	8 hours with operating Defibrillation/Patient monitor 5 hours with power off
Dual Battery:	Automatic Switching

### Environmental Conditions

Operation	
Temperature:	0 - 50°C (32 - 113°F)
Humidity:	5 - 95% RH, non-condensing
Atmospheric pressure:	583.28 ~ 1013.25 hpa (0~4,575m at 25°C)
Water Resistance:	IP34
Transport and Storage (in shipping container)	
Temperature:	-20°C - 60°C (-4°F - 140°F)
Humidity:	5 - 95% RH; non-condensing
Atmospheric pressure:	200.36 ~ 1013.25 hpa (0~12,192m at 25°C)

### Manual Mode

Shock Energy Level

When connecting pads or external paddles:

Adult: 1,2,3,4,5,6,7,8,9,10,15,20,30,40,50,75,100,125,150,175,  
200,300,360 J

Pediatric: 1,2,3,4,5,6,7,8,9,10,15,20,30,40,50,75,100 J

When connecting internal paddles:

Adult/Pediatric: 1,2,3,4,5,6,7,8,9,10,15,20,30,40,50 J

Automatic Discharge Time: 20,60 seconds

Charging Time to 200J: Within 5 sec. at AC/DC rated voltage  
Within 6 sec. with fully charged battery power

Charging Time to 360J: Within 8 sec. at AC/DC rated voltage  
Within 8 sec. with fully charged battery power

Synchronous Cardioversion: Energy transfer begins within 60msec  
of the QRS peak

### AED Mode

1ch ECG measurement

Lead: Lead II  
Patient Impedance: When connecting pads or external paddles:  
25 - 175 Ohm

When connecting internal pads:  
15 - 175 Ohm

Heart Rate: 20 - 300 bpm

Charging Time to 200J: Within 5 sec. at AC/DC rated voltage  
Within 6 sec. with fully charged battery power

### Pacer

Pacing Mode:	Demand or non-demand
Pacing Rate:	30ppm - 180 ppm (The increment unit is 2 bpm)
Accuracy:	± 1,5%
Output current:	0mA - 140mA
Resolution:	2mA
Accuracy:	± 5% or 5mA, whichever is greater
QRS Marker:	In the demand mode

### ECG

Heart Rate	
Measurement Rate:	0,20 - 300 bpm
Resolution:	1 bpm
Accuracy:	±1 bpm or ±1%, whichever is greater
ECG (Electrocardiograph)	
Leads:	3/5/12 Lead Lead I, II, III, aVR, aVL, aVF, V1, V2, V3, V4, V5, V6, Paddles, Pads

Lead Off Detection: Detected and displayed  
Pacer Detection: Detected pacer pulses of ±2mV - ±700mV with  
pulse widths of 0,1 - 2 msec and rise times 10%  
or width not to exceed 100 msec.

#### Input

Input Impedance: 2.5 M Ohm or more (for 0.05 - 40 Hz, with lead  
cable and relay cable)

Input Dynamic Range: ±5mV AC, ±300mV DC

Voltage Range: ±0.3mV ~ ±5mV

Signal Width: 40 - 120 ms (Q-S)

Output (Frequency Response)

ECG Filter	Interpretation	0.05 - 150 Hz
	Low	0.05 - 40 Hz
	Med	0.5 ~ 40 Hz
	High	0.5 ~ 30 Hz
	Hum filter	50 Hz, 60 Hz (not shown or 60 db or over)
	ECG size	Auto, 5.0, 10.0, 15.0, 20.0, 30.0, 40.0 mm/mV

Display Sweep Speeds: 25.0 mm/sec.

Display Sensitivity: 10 mm/mV

Pacing Pulse Detection: On, Off

Electrode Disconnect Alarm: Display and/or sound

Common Mode Rejection (CMRR): 90 dB or more

Defibrillator Discharge Recovery: less than 5 sec. per IEC 60601-2-27

Defibrillation Protection: Protected

# defiMASTER

Biphasic Defibrillation and monitoring

## Interpretive Algorithm

12-Lead Interpretive Algorithm      University of Glasgow 12-Lead ECG Analysis Program

## Respiration

### IM Respiration

Technique: Impedance Pneumography  
Range: 0 ~ 150 bpm  
Resolution: 1 bpm  
Accuracy: ±3 bpm  
Base impedance: 500 - 2000 ohm  
Lead Off Detection: Yes

### AW Respiration

Technique: Non-dispersive Infrared Spectroscopy  
Range: 0 - 150 breaths / min  
Accuracy: ±1 breaths / min

## NIBP

Pulse Rate:  
Pulse Rate Range: Adult/Pediatric/Neonatal 30 - 240 bpm  
Resolution: 1 bpm  
Accuracy: ±5%

### NIBP (Non-Invasive Blood Pressure)

Technique: Oscillometric Measurement  
Measurement Modes: Off, Cont, 1, 2, 2.5, 5, 10, 15, 30, 60, 120 minutes  
Edit program measurement interval

Measurement Range: Adult/Pediatric  
SYS 40 - 270 mmHg  
DIA 20 - 200 mmHg  
Neonatal  
SYS 40 - 120 mmHg  
DIA 20 - 90 mmHg

Accuracy: ±3 mmHg  
Resolution: 1 mmHg  
Initial Cuff Inflate Pressure: Adult/Pediatric

Auto, 120,140,160,180,200,220,240,260,280 mmHg  
(16.0,18.7,21.3,24.0,26.7,29.3,32.0,34.7,37.3 kPa)  
Neonatal  
Auto, 80,100,120,140 mmHg  
(10.7,13.3,16.0,18.7 kPa)

Automated Cuff Protector: Adult/Pediatric 300 mmHg  
Neonatal 150 mmHg

Defibrillator Protection: Protected

## IBP

Pulse Rate  
Pulse Rate Range: Adult/Pediatric/Neonatal 20 - 250 bpm  
Pulse Rate Resolution: 1 bpm  
Pulse Rate Accuracy: ±1 bpm

### IBP (Invasive Blood Pressure)

Measurement Range: BP -50 mmHg - 300 mmHg  
Resolution: BP 1 mmHg  
Input Sensitivity: 5µV/V/mmHg  
Transducer Volume Displacement: 0.1mm<sup>3</sup>/100mmHg  
Zero Calibration Range: -50 ~ 100 mmHg  
Frequency Response: 25 Hz  
Waveform display ratio: Auto, 0~50, 0~100, 0~200, 0~300 mmHg  
Defibrillator Protection: Protected

## Defibrillator

Biphasic Waveform | Biphasic Truncated Exponential  
Resuscitation Guidelines: Selectable AHA/ERC

## SpO2

Measurement Range: 0 ~ 100%  
Accuracy: ±2 digits (70% - 100%) (Unspecified <70%)

## Capnography

Display parameters: EtCO<sub>2</sub>, lnCO<sub>2</sub>  
Measurement Range: 0 - 150 mmHg (0kPa-20kPa, 0%-20%)  
Accuracy: 0 - 40 mmHg ±2 mmHg of reading  
41-70 mmHg ±5% of reading  
71-100 mmHg ±8% of reading  
101-150 mmHg ±10% of reading  
Not decreased according to respiratory rate or I/E ratio

Display Accuracy: ±2 mmHg  
Response Time: Mainstream: Less than 60ms  
Sidestream: Less than 3sec.

Barometric pressure correction: -152.4-4572 m (-500 - 15,000 feet),  
775 - 429 mmHg, Auto

Gas Compensation: User selective at O<sub>2</sub> > 60% and N<sub>2</sub>O > 50%  
Stability: Short term drift: Less than 0.8 mmHg over 4 hours  
Long term drift: Maintain accuracy over 120 hours

Accuracy change due to gas and chemical interference: 0-40mmHg ±1 mmHg Additional Error  
41-70mmHg ±2.5% Additional Error  
71-100 mmHg ±4% Additional Error  
101-150 mmHg ±5% Additional Error

Measurement preparation time: 2 minutes maximum

Sweep Speeds: 6.25, 12.5, 25.0 mm/s

Extraction rate: 100 Hz

Sound Noise Level: Less than 41dB (when ambient noise level is 22dB)

## Temperature

Probe Types: Thermistor probe YSI compatible type  
Measurement Range: 0.0 - 50°C (32.0 - 122°F)  
Resolution: 0.1°C  
Defibrillator Protection: Protected

## Trend

Type: 12 lead, Events, Trend  
Data Storage: Internal memory, SD card  
Memory: **12 lead**  
Saves total 100 data  
Saves ECG waveform, ECG analysis result/data/  
date/time, HR/PR, NIBP, SpO<sub>2</sub>, Respiration, IBP,  
Temperature, EtCo<sub>2</sub> numeric data, alarm condition

## Event

Saves total 250 data  
Saves defibrillation shock information (number of shock, energy selection, actual passed energy, impedance)  
Pacing information (pace rate, pace current, async mode)  
Clinical action list  
1 channel ECG waveform  
Event date and time  
HR/PR, NIBP, SpO<sub>2</sub>, Respiration, Temperature, IBP,  
EtCo<sub>2</sub> numeric, data, alarm condition

## Trend

Saves total 200 data  
Saves date and time  
HR/PR, NIBP, SpO<sub>2</sub>, Respiration, Temperature, IBP,  
EtCo<sub>2</sub> numeric data, alarm condition



# defiMASTER

Biphasic Defibrillation and monitoring

## Optional Items

Non-Invasive Blood Pressure with cuffs and cuffs hoses  
SpO2 (Nellcor) with DS-100A and DOC-10  
12 Lead ECG with Interpretation from the University of Glasgow  
Continuous Temperature Monitoring  
EtCo2, selectable either Mainstream or Sidestream  
Invasive Blood Pressure Monitoring (2 lines)  
Wi-Fi/3G Communication module  
Wireless LAN data transmission  
Additional Battery

## Dimensions

Left

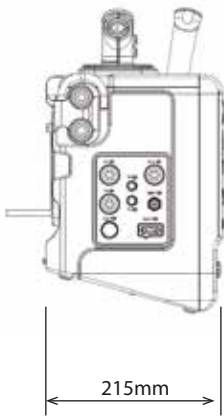

Front



Right

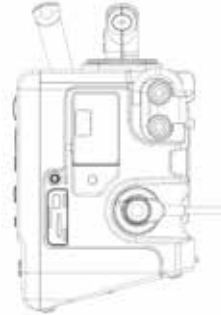

Back



## Cradle (Optional)

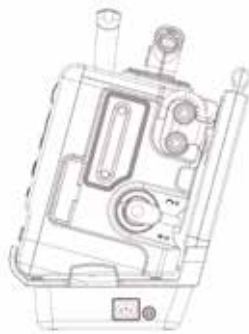
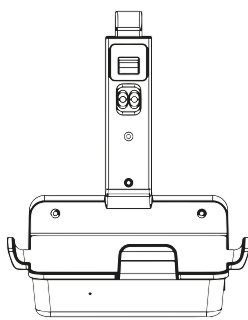

## Packaging

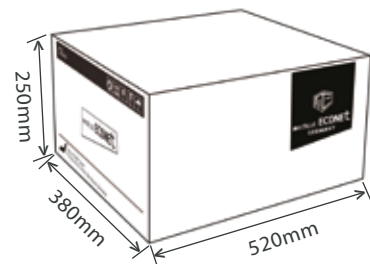

Approx. 7kg

## Weiterführende Informationsmedien: *Available further product information:*



Image Broschüre defiMASTER  
*Image brochure defiMASTER*



Detailliertes Spezifikationsdatenblatt defiMASTER  
*Detailed specification sheet for defiMASTER*

## Contact details:

medical ECONT GmbH  
Im Erlengrund 20  
46149 Oberhausen  
Germany

t: +49 (0)208 / 377 890 - 0  
f: +49 (0)208 / 377 890 - 55  
e: [info@medical-econet.com](mailto:info@medical-econet.com)

[www.medical-econet.com](http://www.medical-econet.com)

[facebook.com/medicaleconetgermany](https://facebook.com/medicaleconetgermany)  
[twitter.com/medicaleconet](https://twitter.com/medicaleconet)  
[youtube.com/medicalECONETGmbH](https://youtube.com/medicalECONETGmbH)



medical **ECONET**

medical ECONET GmbH  
Im Erlengrund 20 46149 Oberhausen Germany  
[www.medical-econet.com](http://www.medical-econet.com)

Distributor